

ACC500 / ACC600 AUTOMATIC CUTTING CENTER WITH AUTO LOADING MAGAZINE

The ACC500/600 Cutting Center with 2 controlled axes is designed for the accurate positioning and cutting of aluminum and PVC profiles. This fully automated unit, once loaded, requires no operator during its cutting cycle. The cutting center will feed an entire length of extrusion, rotate if necessary cut and offload the finished pieces automatically. The unit is capable of rotating to obtain cuts at 45°, 90° and 135°. A tilting version from 45° to 90° is available upon special request. The powerful and versatile software can handle predefined cutting lists and optimize for reduced waste.

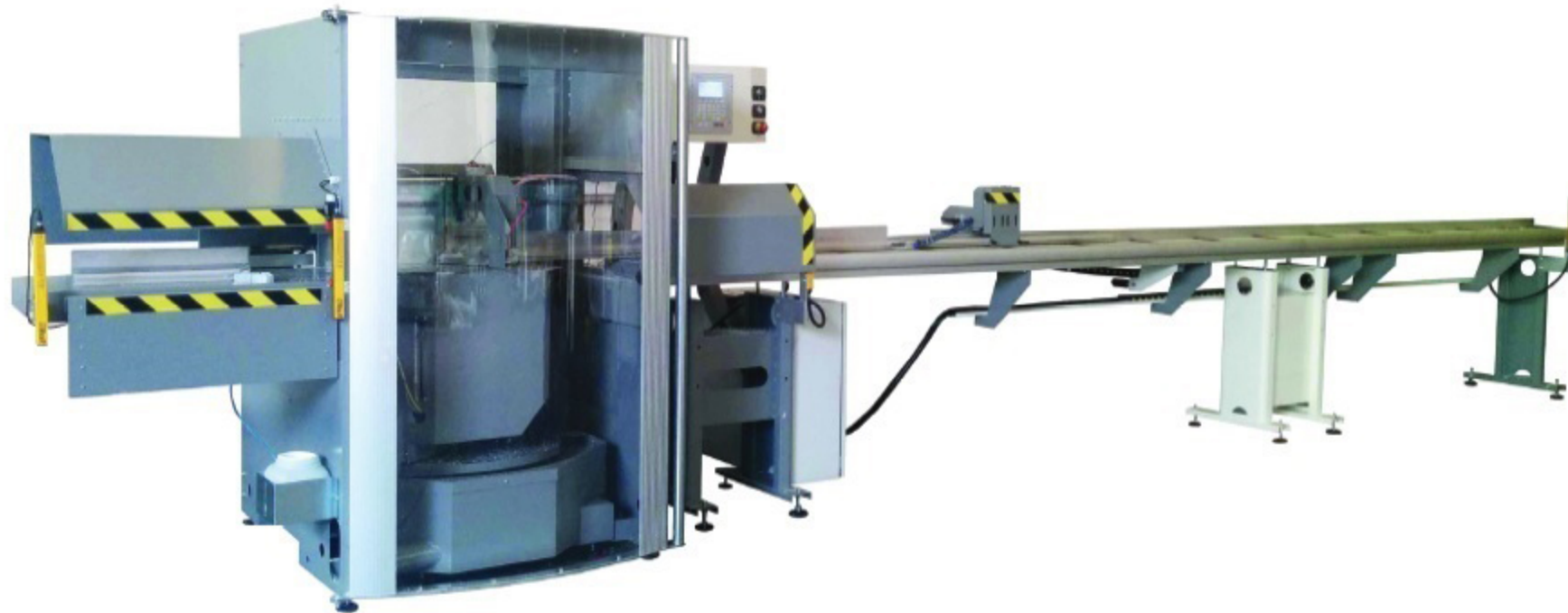

The machine is made of 3 main parts

1. Loading side:

- Automatic rolling table with pinch to hold and move the profile, 7 meters long; the maximum speed of the carriage is 50 m/min.



2. Cutting side:

- Single head cutting machine ACC500 with a Ø500 or ACC600 Ø600 mm blade and pneumatic rotation of the head to 45°/90°/135°; the blade motor is a 4 kW 2800 rpm; a cabin protect the access to the cutting area.

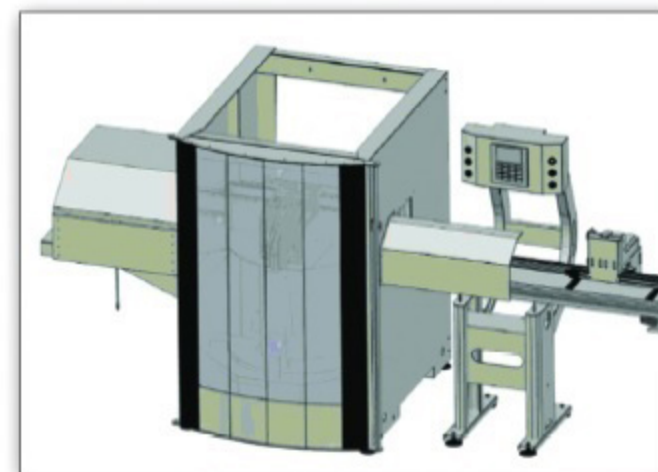

3. Unloading side:

- The unloading table is 2.5 meters long and receives the pieces that are pushed away from the cutting machine and pushes them forward.
- The unloading area is protected with a protection door and with safety light curtains to ensure the maximum safety of the operator.

TECHNICAL SPECIFICATIONS:

- Loading table length: 7000 mm
- Minimum cutting length at 90°: 0 mm
- Magnetic band measuring system
- Positioning tolerance: ± 0.1 mm
- Loading capacity: 30 kg/m
- Blade motor: 4kW
- Table width: 200 mm
- Industrial CNC
- All movements on linear high precision guide ways
- Max speed 50 m/min
- Rolling table made with aluminum extrusions

COMPONENTS SUPPLIED:

- Label printer
- Rotation of the cutting head CNC controlled
- Dust extractor with 2.2 kW motor

OPTIONS :

- Personalization for the label printer
- 1 meter extra long loading table

IMPORTANT!

To ensure the maximum safety of the operator the machine must be surrounded by safety guards that are not included in this offer and must be made by the customer.

Example:

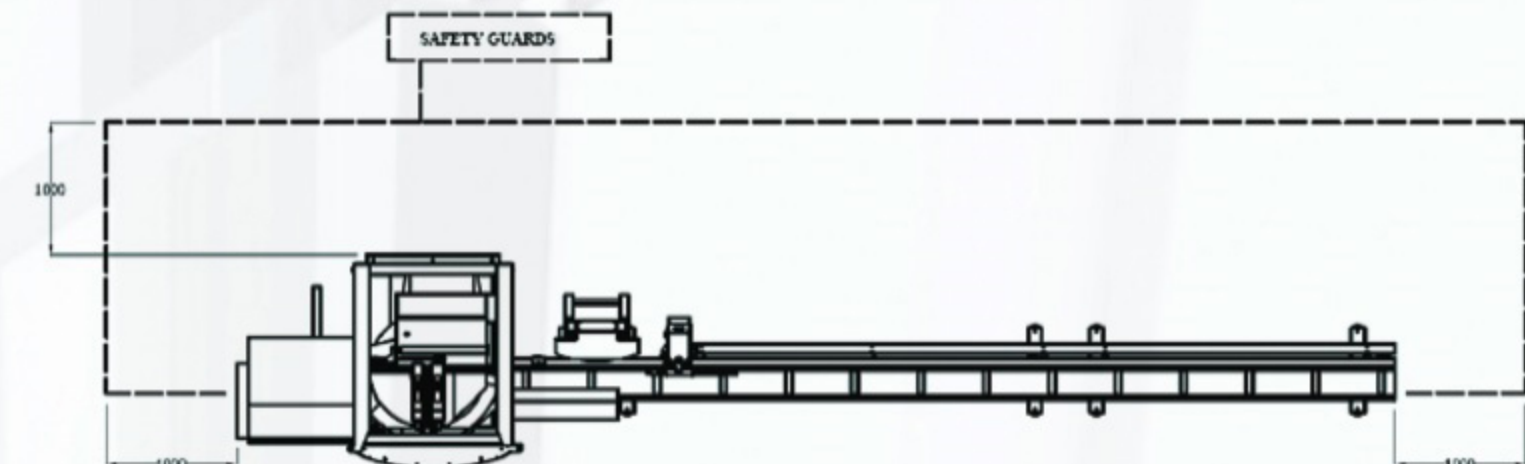

Bar positioning

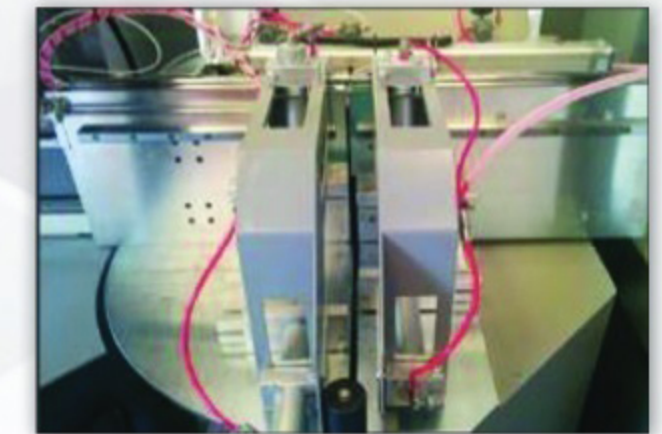

Cutting unit